

HUSSMANN®

HGM-2TS

Vertical Glass Door Merchandiser for Dairy, Deli, and Beverages



*HGM-TS Optional
Lighted Sign*

BEVERAGES

IR Ingersoll Rand

Self-Contained and Remote HGM Vertical Glass Door Merchandisers

HUSSMANN®

HGM-1TS, HGM-2TS, HGM-3TS Top Mount Medium Temperature for Dairy, Deli and Beverages

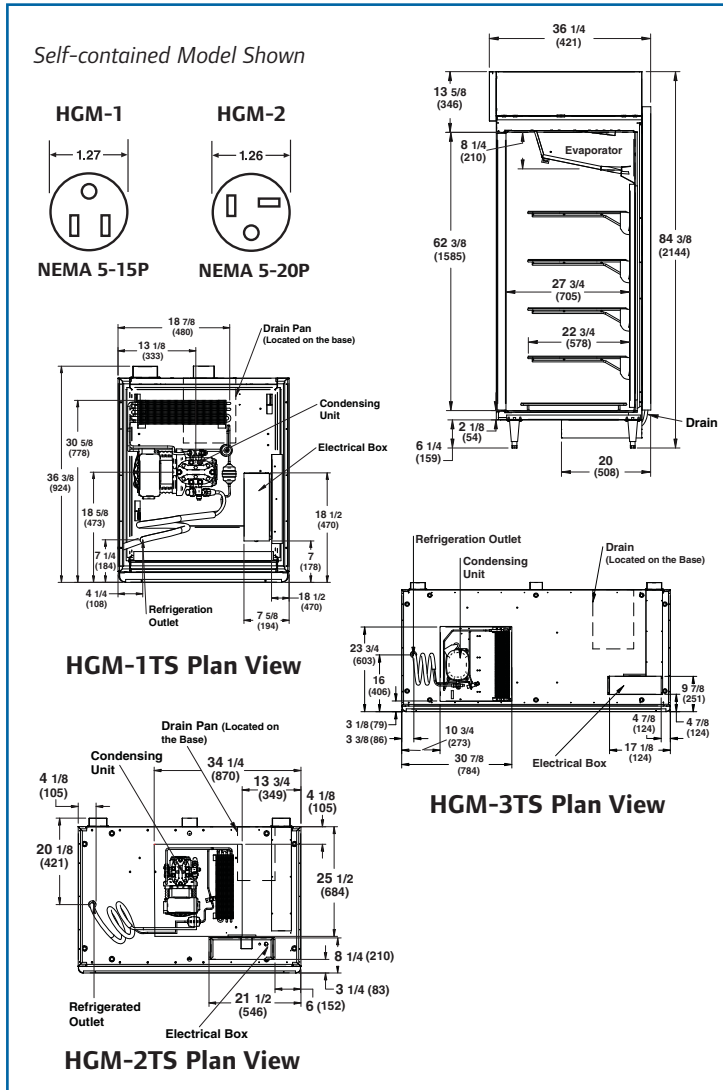

Standard Features

- Contemporary styling places maximum attention on merchandising. All HGM merchandisers have the same access panel design for commonality between merchandisers.
- Improved product visibility and energy savings with LED lighting. Merchandise is evenly illuminated throughout display area. More lights per merchandiser with two lights in single-door, three-lights in two-door, and four lights in three-door models.
- White powder coated exterior and interior finish.
- CFC-Free foamed-in-place urethane insulation.
- Doors can be locked open for stocking.
- Each door section includes four adjustable cantilever-type shelves and a bottom rack. All shelves and racks have a white epoxy coated finish. Shelves may be slanted for special displays and are interchangeable in all models.
- Full use of the shelf upright posts is available for positioning the shelves. Shelf bracket profiles have been slimmed down to better facilitate product merchandising under and across the shelves.
- The HGM-1TS and HGM-2TS are equipped with 115 volt power cord (see diagram). The HGM-3TS requires field wiring to 115 volt service.
- Each cabinet furnished with 6" adjustable legs.
- Easy-to-read digital solar powered thermometer. Electronic temperature control ensures consistent product temperature.

Matching Low Temperature Models

For a matching side-by-side display of frozen foods and ice cream, be sure to see the companion HGL-TS series of low temperature 1-, 2-, and 3-door models.

Warranty

For detailed warranty information, visit www.hussmann.com.

Optional Accessories

- Variety of Exterior Colors
- Three Tier Step Rack
- Price Tag Moulding
- Baskets
- Shelf Product Stop
- Additional Display Shelves
- Door Guard
- Peg Bar and Hooks
- End Windows
- Lighted Sign
- Skirt Kit
- Can Dispensing Rack
- Door Lock

Model	Refrigeration load (BTU/h)	A/C load (BTU/h)	Energy Consumpt. (kWh/day)
HGM-1TS	1870	2575	5.46
HGM-1T		—	—
HGM-2TS	2300	3165	8.96
HGM-2T		—	—
HGM-3TS	4270	5875	9.84
HGM-3T		—	—



Model	Exterior Dimensions			Nominal H.P.	Refrig.	Electrical				Apprx. Ship Wt. (LBS)	
	L	D*	H			Hz/Ph	Volts	Run Amps	Fuse Amps		NEMA Plug
HGM-1TS	28 7/8"	36 1/4"	84 3/8"	1/3	R-134a	60/1	115	11.8	15	5-15P	562
HGM-1T	28 7/8"	36 1/4"	84 3/8"	—	R-134a	60/1	115	5.3	15	hardwired	489
HGM-2TS	52"	36 1/4"	84 3/8"	1/2	R-134a	60/1	115	12.5	20	5-20P	776
HGM-2T	52"	36 1/4"	84 3/8"	—	R-134a	60/1	115	6.0	15	hardwired	681
HGM-3TS	75 3/8"	36 1/4"	84 3/8"	3/4	R-134a	60/1	115	20.5	30	hardwired	1050
HGM-3T	75 3/8"	36 1/4"	84 3/8"	—	R-134a	60/1	115	8.0	15	hardwired	945

*Exclusive of door handles.

Web Site: www.hussmann.com



We reserve the right to change or revise specifications and product design in connection with any feature of our products. Such changes do not entitle the buyer to corresponding changes, improvements, additions, or replacements for equipment previously sold or shipped. Case is designed for holding pre-chilled product only.

NOTE: For optimum performance, these models are designed for use in air-conditioned stores where temperature and humidity are maintained at 75°F and 55% R.H. Locate case away from direct sunlight, rapid air currents and extreme temperature changes.